

# **BAS RTP-B**

## **Portable BACnet<sup>®</sup> Multi-Network Router**

### **Installation Guide**

TD070210-01E

For Firmware Versions 2.x

---

## Trademarks

Contemporary Controls, ARC Control, ARC DETECT, EXTEND-A-BUS, RapidRing, and CTRLink are trademarks or registered trademarks of Contemporary Control Systems, Inc. Specifications are subject to change without notice. Other product names may be trademarks or registered trademarks of their respective companies. BACnet is a registered trademark of the American Society of Heating, Refrigeration, and Air-Conditioning Engineers, Inc. (ASHRAE).

TD070210-0IE 28 October 2010

## Copyright

© Copyright 2010 by Contemporary Control Systems, Inc. All rights reserved. No part of this publication may be reproduced, transmitted, transcribed, stored in a retrieval system, or translated into any language or computer language, in any form or by any means, electronic, mechanical, magnetic, optical, chemical, manual, or otherwise, without the prior written permission of:

**Contemporary Control Systems, Inc.**  
2431 Curtiss Street  
Downers Grove, Illinois 60515 USA  
Tel: 1-630-963-7070  
Fax: 1-630-963-0109  
E-mail: [info@ccontrols.com](mailto:info@ccontrols.com)  
Web: [www.ccontrols.com](http://www.ccontrols.com)

**Contemporary Controls Ltd**  
14 Bow Court, Fletchworth Gate  
Coventry CV5 6SP UK  
Tel: +44 (0)24 7641 3786  
Fax: +44 (0)24 7641 3923  
E-mail: [info@ccontrols.co.uk](mailto:info@ccontrols.co.uk)  
Web: [www.ccontrols.co.uk](http://www.ccontrols.co.uk)

**Contemporary Controls (Suzhou) Co. Ltd**  
11 Huoju Road, Science & Technology Park  
New District, Suzhou, PR China 215009  
Tel: +86-512-68095866  
Fax: +86-512-68093760  
E-mail: [info@ccontrols.com.cn](mailto:info@ccontrols.com.cn)  
Web: [www.ccontrols.com.cn](http://www.ccontrols.com.cn)

**Contemporary Controls GmbH**  
Fuggerstraße 1 B  
04158 Leipzig, Germany  
Tel: +49-0341-520359-0  
Fax: +49-0341-520359-16  
E-mail: [info@ccontrols.de](mailto:info@ccontrols.de)  
Web: [www.ccontrols.de](http://www.ccontrols.de)

## Disclaimer

Contemporary Control Systems, Inc. reserves the right to make changes in the specifications of the product described within this manual at any time without notice and without obligation of Contemporary Control Systems, Inc. to notify any person of such revision or change.

# Contents

---

1	Introduction.....	4
2	Specifications .....	5
	Electrical .....	5
	Environmental.....	5
	Functional .....	5
	Electromagnetic Compatibility .....	5
	Connectors .....	6
	Mechanical.....	6
3	Power .....	7
4	Operation .....	9
	MS/TP Port .....	9
	Ethernet Port .....	9
	IP Address Reset Switch .....	9
	LEDS .....	9
5	Webpage Configuration .....	10
	Device Parameter .....	13
	BACnet Ethernet.....	13
	BACnet/IP Parameters .....	14
	MS/TP Parameters .....	15
	Status Screen.....	16
6	Warranty .....	18
	Returning Products for Repair .....	18
7	Declaration of Conformity .....	18

---

# 1 Introduction

The BASRTP-B is a multi-network router, sharing messages among BACnet/IP, BACnet Ethernet and MS/TP networks. The router is configurable via its internal webpage. The unit attaches to a USB port of your computer and has one isolated MS/TP port and one 10/100 Mbps Ethernet Auto-MDIX port.

**The MS/TP port** offers a 3-pin terminal block with a removable plug for the EIA-485 connection. Through this port, up to 254 devices can be addressed — as many as 31 full-load devices on the attached segment. All MS/TP baud rates (as stated in the BACnet standard) are supported.

**The Ethernet port** offers a shielded RJ-45 connector. Through auto-negotiation and Auto-MDIX, it automatically matches its duplex setting, data rate and signal polarity to whatever is needed by the attached equipment. Thus, only a straight-through CAT5 cable is needed for hook-up.

The USB port is strictly used to power the BASRTP-B. No communications is supported via the USB port.

The BASRTP-B features a user-accessible switch to reset the IP address, subnet mask and gateway address to the factory defaults.

Three LEDs are present: A power LED glows green when proper power is provided. The Ethernet LED glows green for 100 Mbps operation and yellow for 10 Mbps and flashes to indicate activity. A green LED flashes when MS/TP traffic is received.

Each unit complies with Class A radiated and conducted emissions as defined by EN55022 and CFR 47, Part 15, and is intended for use in non-residential areas.

---

## 2 Specifications

### *Electrical*

INPUT	USB (Type B Port)
Voltage (V, nominal):	5 VDC
Current (mA, typical):	300
Power:	2.5 W

### *Environmental*

Operating temperature:	0°C to 60°C
Storage temperature:	-40°C to +85°C
Relative humidity:	10–95%, non-condensing

### *Functional*

	Ethernet	<i>MS/TP</i>
Signalling:	10BASE-T	<i>EIA-485</i>
	100BASE-TX	<i>(ANSI/ASHRAE 135-2008)</i>
Cable length limit:	100 m	<i>1200 m (for AWG 18)</i>
MS/TP Baud rate (bps):	9600, 19200, 38400, 76800	
MS/TP node limit:	254 devices total 31 full-load devices per segment	
MS/TP LED:	flashing green = receive valid activity	
Ethernet LED:	green = 100 Mbps yellow = 10 Mbps flashing = activity	

### *Regulatory Compliance*

CE Mark; RoHS; CFR47, Part 15 Class A

### *Electromagnetic Compatibility*

Each unit complies with Class A radiated and conducted emissions as defined by EN55022 and CFR 47, Part 15. This equipment is intended for use in non-residential areas.

**Warning** This is a Class A product as defined in EN55022. In a domestic environment this product may cause radio interference in which case the user may be required to take adequate measures.

---

## Connectors

### 3-pin (MS/TP) Pin Assignments

(Also explained on product label)

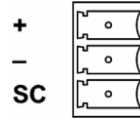

Figure 1 — 3-pin Connector

### RJ-11 (MS/TP) Pin Assignments

- 2 RT -
- 4 SC
- 5 RT +

(All other pins are unused.)

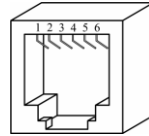

Figure 2 — RJ-11 Connector

### RJ-45 (MDI Ethernet) Pin Assignments

- 1 TD +      3 RD +
- 2 TD -      6 RD -

(All other pins are unused.)

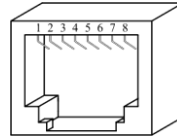

Figure 3 — RJ-45 Connector

## Mechanical

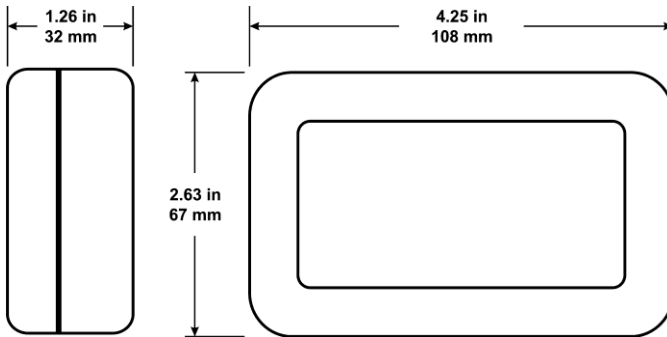

Figure 4 — Product Dimensions

### 3 Power

The BASRTP-B features a USB 2.0 Full Speed Device Port that accepts the USB cable with Type B plug that is included in the box. It takes 5 VDC from a host computer, while typically drawing 300 mA of current. It can operate from a USB hub, if desired, and no driver installation is needed.

For MS/TP devices, see Figure 5 for proper 2-wire bus connections and Figure 6 for proper 3-wire bus connections. The BASRTP-B does not apply any failsafe bias or termination.

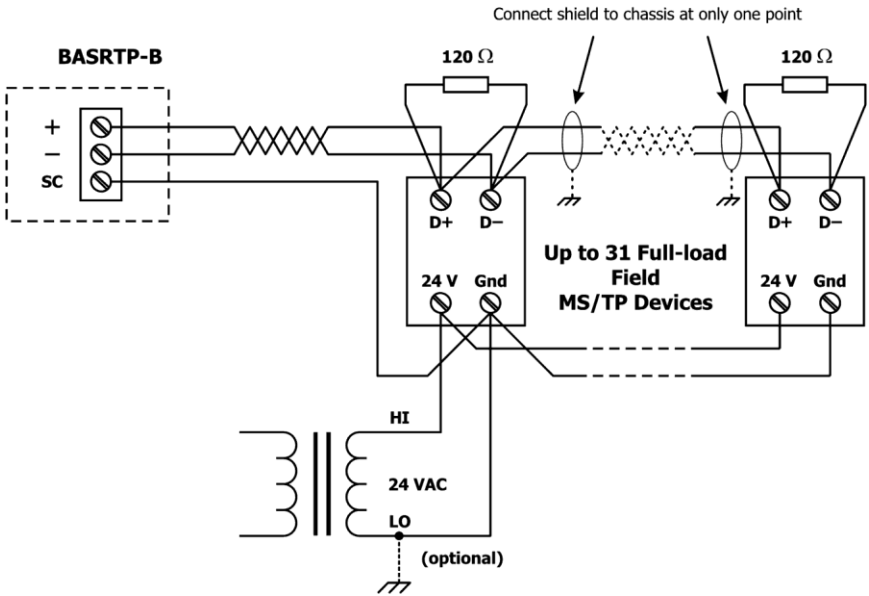

Figure 5 — 2-wire MS/TP Bus Wiring

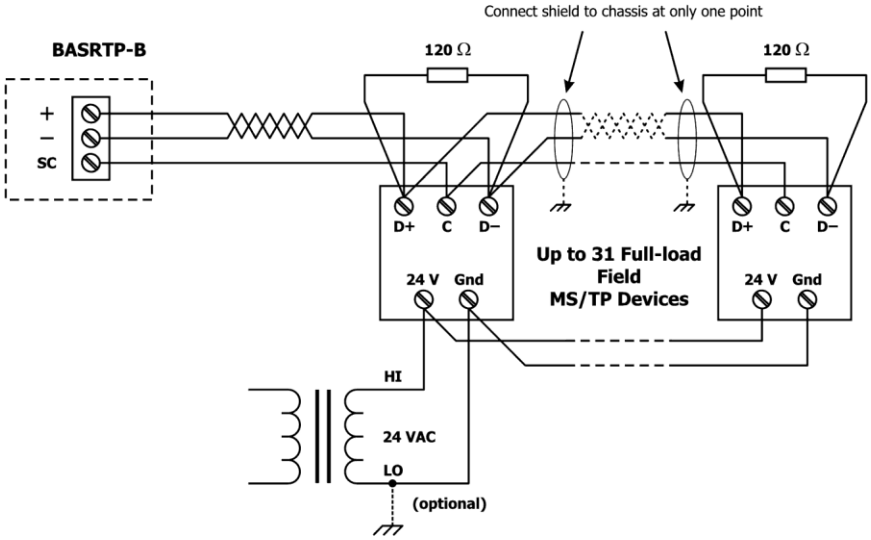

Figure 6 — 3-wire MS/TP Bus Wiring

---

## 4 Operation

### *MS/TP Port*

The MS/TP port uses an isolated EIA-485 transceiver that is connected to both a removable 3-pin connector (*Figure 1*) and an RJ-11 jack. Either connector can be used for the MS/TP line. The EIA-485 transceiver's + and – lines tie to + and – pins of both connectors. The SC pin ties to the circuit ground of the EIA-485 transceiver and is isolated from both the USB and Ethernet ports.

The router can access 254 MS/TP devices and supports 31 devices on the local bus at rates of 9600, 19200, 38400, or 76800 bps.

### *Ethernet Port*

This port offers a shielded RJ-45 connector. Through auto-negotiation and Auto-MDIX, it automatically matches its duplex setting, flow control, data rate and signal polarity to whatever is needed by the attached equipment. Thus, the provided CAT5 cable is the only cable needed for the Ethernet hook-up.

### *IP Address Reset Switch*

When pressed for at least 1 second (at any time the router is under power), this switch will reset the default values of the address (192.168.92.68), gateway (192.168.92.1) and netmask (24). It is accessed by a paper clip (or similar device) via a small hole in the case — then after reboot, the default values apply.

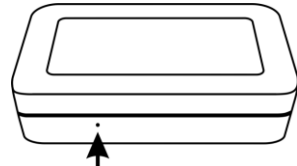

**Figure 7 — Reset Switch** (at any switch IP address device)

### *LEDS*

- Power* glows green if power supplied to the unit is proper
- Ethernet* glows solid for a valid link (green for 100 Mbps or yellow for 10 Mbps) and flashes to show activity
- MS/TP* flashes green when receiving valid MS/TP traffic

---

## 5 Webpage Configuration

Each router contains an interactive web server, accessible from any Internet-compatible PC on the local network and compatible with recent versions of Internet Explorer (5.0 or later, suggested) or Netscape Navigator (7.1 or later, required). It is factory-programmed with a default IP address of 192.168.92.68 and a Class C subnet mask of 255.255.255.0 (/24).

*Figure 8* shows the setup for accessing the MS/TP network using the BASRTP-B, a computer for configuration, and a connection to the MS/TP network. Make sure that a USB cable connects between the PC and the BASRTP-B so it can be powered.

To configure the router, attach it to a computer with an Ethernet connection and a standard web browser. For initial configuration, the PC chosen for the procedure should temporarily have its IP address modified as illustrated in *Figure 9* — which employs a Windows<sup>®</sup> XP example.

The example in *Figure 9* suggests an IP address for the PC of 192.168.92.69, but the final quad of the address could be any value from 3 to 254 — except for 68 which is used by the router. After the IP address of the PC has been set to the same subnet as the router, a browser can access the router via its default IP address.



*Figure 8 — Setup for Initial IP Address Configuration*

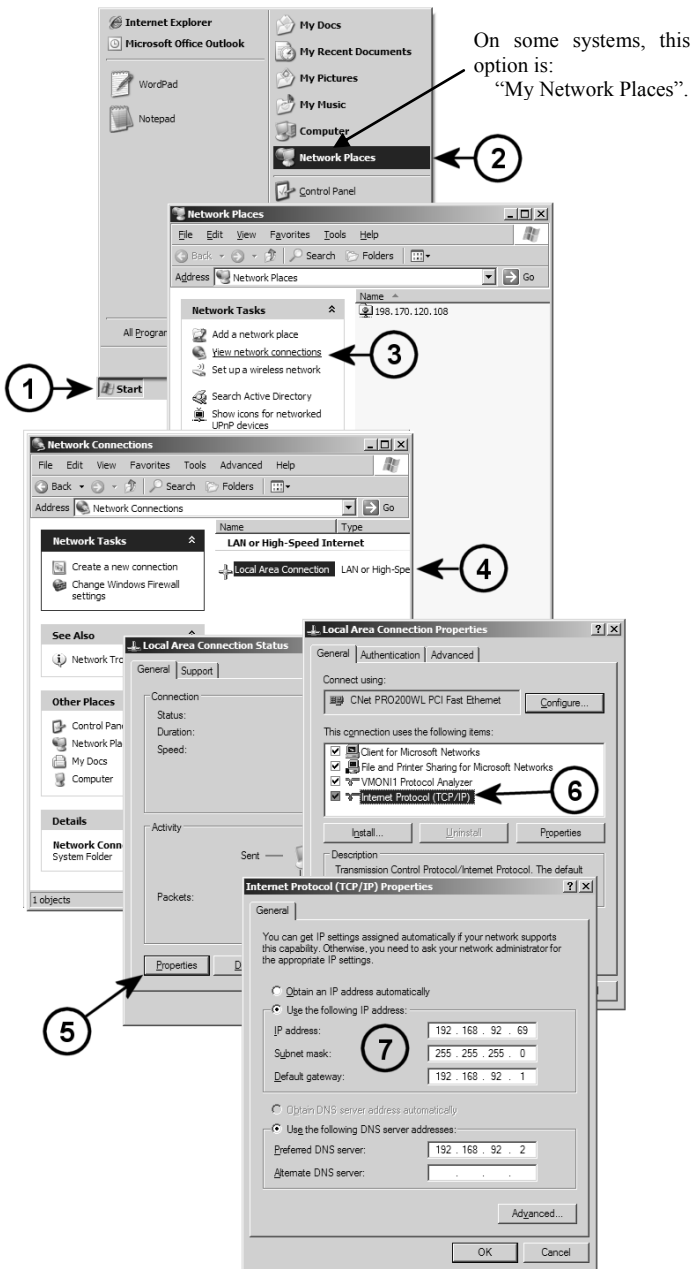

Figure 9 — Steps for Changing the IP Address of the PC Used for Setup

After entering the router's IP address into your browser's address field, you will see the Router Configuration Page with the default values as shown in *Figure 10* — using Windows Internet Explorer.



*Figure 10 — Router Configuration Page with Default Values*

Each parameter of the configuration is explained on the following pages. When *save changes* is selected, the parameters are stored to non-volatile memory and you are prompted to recycle power to the unit.

---

## ***Device Parameter***

### ***Device Instance (Default Value = 0)***

The router's device instance is a 22-bit value (0–4,194,302). Do not use 4,194,303 which is reserved by BACnet. Each BACnet device within the same BACnet internetwork must have a unique device instance. One must be assigned to the BASRTP-B.

### ***BACnet Ethernet***

#### ***Ethernet Network (Default Value = 0 — disables BACnet Ethernet)***

Most BACnet communication that is carried by Ethernet uses the *BACnet/IP* protocol. However, there are still instances in which the older *BACnet Ethernet* protocol (ISO 8802-3) is found. The BASRTP-B allows these two protocols to communicate.

BACnet Ethernet uses *Ethernet MAC addresses* for station addressing — unlike BACnet/IP which addresses messages by means of *Internet Protocol (IP) addresses*. Each Ethernet MAC address (often called the *physical address*) is unique to the Ethernet network adapter. It is permanently embedded into the adapter during manufacture and cannot be changed. It is composed of six two-digit *hexadecimal* numbers (00–FF). An example of an Ethernet MAC address is:

**00-08-A1-10-BD-EB**

Each Ethernet network adapter has the ability to store an IP address that is *changeable*. This IP address is typically represented as four *decimal* values (each is 0–255) separated by dots. Often called the *dotted quad format*, an example is:

**192.168.92.1**

**NOTE:** Although they may share the same Ethernet physical network, BACnet Ethernet devices and BACnet/IP devices must have their own unique network number and these two networks *cannot communicate* unless their messages pass through a router. These network numbers must be in the range of 1–65534 (0 and 65535 are reserved). If the BACnet Ethernet network value is left at its default value of 0, the BACnet Ethernet function within the BASRTP-B ***will be disabled***. To prevent message loops, a subnet must have only ***one router enabled*** for BACnet Ethernet.

---

## ***BACnet/IP Parameters***

### ***BACnet/IP UDP Port (Default Value = 0xBAC0)***

This 16-bit hex value (BAC0–BACF) is set to BAC0 by default. Usually, this default value should not be changed. In a typical installation, each BASRTP-B will be assigned the same UDP port.

### ***BACnet/IP Network (Default Value = 1)***

The BACnet/IP network number is a 16-bit value (1–65534). Each network within the BACnet internetwork must have a unique number. This includes the BACnet/IP and MS/TP sides of the BASRTP-B. Do not use addresses 0 or 65535 since these addresses are reserved.

### ***IP Address (Default Value = 192.168.92.68)***

The IP address of the router can be 0.0.0.1–255.255.255.254. A private address is usually assigned to the BASRTP-B.

### ***IP Subnet (Default Value = 24)***

This value (0–30 in the “slash” notation) is the number of *bits* with a “1” in the mask. The default value of 24 corresponds to 255.255.255.0 in the dotted *decimal* format. All devices on the same subnet which communicate via BACnet/IP should use the same subnet mask.

### ***IP Gateway (Default Value = 192.168.92.1)***

The default gateway for the IP stack is a dotted decimal number in the range of 0.0.0.0–255.255.255.254. This will be the IP address of your local IP router — if one exists.

---

## ***MS/TP Parameters***

### ***MS/TP MAC (Default Value = 00)***

This is the 8-bit (0–127) MAC address of the router’s MS/TP port, in decimal. Lower MAC address numbers are preferred with the default recommended. It is further recommended that all other BACnet devices attached to the same MS/TP network be assigned consecutive MAC addresses beginning with 1 without allowing any gaps in addressing. Slave devices may have MAC addresses of 128–254, but MAC address 255 is reserved.

### ***MS/TP Network (Default Value = 2001)***

This 16-bit decimal network number (1–65534) must be unique for all BACnet networks within the BACnet internetwork. No other networks, regardless of type, can have the same network number. Do not use addresses 0 or 65535 since these addresses are reserved.

### ***Max Masters (Default Value = 127)***

Only master nodes participate in the MS/TP token-passing process. The highest master MAC address (in decimal) in the MS/TP network is 127 and you should use 127 if you are unsure of other MS/TP device addresses. Each MS/TP device should use this same value. For a value in this field to be proper, it must equal or exceed the highest MAC address for any master on the network. Optimum performance occurs when this value:

1. ***equals*** the highest MAC address of any master, and
2. all masters use ***sequential*** MAC addresses

Since many BACnet devices do not allow this parameter to be changed, leave the BASRTP-B at the default value.

### ***Max Info Frames (Default Value = 40)***

This is the maximum number of messages that can be routed onto the MS/TP network by the router per token pass. Its range is 1–100, and typical values are 20–40. Smaller values provide less access to the MS/TP network from the BACnet/IP network because they give native MS/TP messages higher priority than those passed by the router from BACnet/IP. The default value usually provides good performance.

---

### *MS/TP Baud Rate (Default Value = 9600)*

The baud rate of the MS/TP network can be 9600, 19200, 38400 or 76800 bps. All MS/TP devices on the same MS/TP network must use the same baud rate. On power up the router checks for other masters; if finding none, it begins token passing — at which point autobauding devices will adjust to the router's baud rate.

### *MS/TP Tolerance (Default Selection = Strict)*

This setting determines the degree to which interoperability with devices is successful. The Lenient option is less efficient for traffic flow but optimises interoperability. A slight improvement in performance will be realised by selecting the *Strict* setting.

### *Status Screen*

The Status Screen depicted in Figure 11 reports the traffic of the various protocols handled by the BASRTP-B. It shows the number of messages received and transmitted for each of the supported networks.

**Note:** “BIP 1” is the only BACnet/IP port in use. Although it appears in the screen, “BIP 2” is not used in this version of the product. Therefore, the counts of “BIP 2 Incoming Packets” and “BIP 2 Outgoing packets” will always be 0.

“Available Memory” (at the bottom of the list) is the amount of RAM currently unused (normally about 30K). If one network is temporarily offline and another network is attempting to communicate with this network, the available memory may drop very low until the offline network returns to an online condition.

The remaining information indicates the instantaneous MS/TP state of the router and is documented in the MS/TP portion of the BACnet standard.

“RFSM” is the current *Receive Frame State Machine* state.

“MNSM” is the current *Master Node State Machine* state.

By refreshing this page, you can watch the router MS/TP state change and gain insight into the state of the MS/TP network (as seen by the router). For example, if “MNSM” always reports *SoleMaster*

---

or *PollForMaster*, after repeated refreshes, then the router cannot communicate with any MS/TP devices.

“Next Station” is the MS/TP MAC address of the device to which the router will next pass the token. This value may change if devices leave or enter the network — and when the router searches for devices on the network, as per the BACnet MS/TP standard.

```
BIP 1 Incoming Packets=440
BIP 1 Outgoing Packets=440
BIP 2 Incoming Packets=0
BIP 2 Outgoing Packets=0
BACnet/Ethernet Incoming Packets=0
BACnet/Ethernet Outgoing Packets=1
MSTP Incoming Packets=439
MSTP Outgoing Packets=440
SilenceTimer=6
EventCount=62
flags=0 0
RFSM state=02 Header
MNSM state=01 Idle
Next Station=1
Poll Station=0
Available Memory=34859
```

**Figure 11 — Status Screen**

---

## 6 Warranty

Contemporary Controls (CC) warrants this product to the original purchaser for two years from the product shipping date. Product returned to CC for repair is warranted for one year from the date the repaired product is shipped back to the purchaser or for the remainder of the original warranty period, whichever is longer.

If the product fails to operate in compliance with its specification during the warranty period, CC will, at its option, repair or replace the product at no charge. The customer is, however, responsible for shipping the product; CC assumes no responsibility for the product until it is received.

CC's limited warranty covers products only as delivered and does not cover repair of products that have been damaged by abuse, accident, disaster, misuse, or incorrect installation. User modification may void the warranty if the product is damaged by the modification, in which case this warranty does not cover repair or replacement.

This warranty in no way warrants suitability of the product for any specific application. IN NO EVENT WILL CC BE LIABLE FOR ANY DAMAGES INCLUDING LOST PROFITS, LOST SAVINGS, OR OTHER INCIDENTAL OR CONSEQUENTIAL DAMAGES ARISING OUT OF THE USE OR INABILITY TO USE THE PRODUCT EVEN IF CC HAS BEEN ADVISED OF THE POSSIBILITY OF SUCH DAMAGES, OR FOR ANY CLAIM BY ANY PARTY OTHER THAN THE PURCHASER.

THE ABOVE WARRANTY IS IN LIEU OF ANY AND ALL OTHER WARRANTIES, EXPRESSED OR IMPLIED OR STATUTORY, INCLUDING THE WARRANTIES OF MERCHANTABILITY, FITNESS FOR PARTICULAR PURPOSE OR USE, TITLE AND NONINFRINGEMENT.

### *Returning Products for Repair*

Return the product to the location where it was purchased by following the instructions at the URL below:

[www.ccontrols.com/rma.htm](http://www.ccontrols.com/rma.htm)

## 7 Declaration of Conformity

Information about the regulatory compliance of this product can be found at the URL below:

[www.ccontrols.com/compliance.htm](http://www.ccontrols.com/compliance.htm)

October 2010

TD070210-01E

---

[This page is intentionally left blank.]

---

[This page is intentionally left blank.]